

User Manual



22 X INDOOR PTZ DOME CAMERA

Model RELPTZ22-1
12 VDC/650 mA NTSC

Publication No. RELPTZ22-10B

Safety 1st

REVO America wants to ensure that your installation experience is a safe and pleasant one. Please read and adhere to these Safety Instructions.



CAUTION

Model RELPTZ22-1 is an indoor camera and not meant for outdoor use. Doing so will void the warranty.

Never perform any installation procedure or open the camera case with power on.

- 1. Pay attention to the Warnings and Cautions in the instructions. They are there for your safety and to ensure that the equipment does not get damaged.**
- 2. Do not discard this manual after installation. You may need to reference it in the future.**
- 3. Use a Certified/Listed Class 2 power supply only.**
- 4. Do not block any ventilation openings. Install in accordance with the manufacturer's instructions.**
- 5. Do not install near any heat sources such as radiators, heat registers, stoves, or other apparatus (including amplifiers) that produce heat.**
- 6. Do not defeat the safety purpose of the polarized or grounding-type plug. A polarized plug has two blades with one wider than the other. A grounding type plug has two blades and a third grounding prong. The wide blade or the third prong are provided for your safety. If the provided plug does not fit into your outlet, DO NOT MODIFY THE PLUG OR OUTLET. Consult an electrician for replacement of the obsolete outlet.**
- 7. Protect the power cord from being walked on or pinched particularly at plugs, convenience receptacles, and the point where they exit from the apparatus.**
- 8. Only use attachments/accessories specified by the manufacturer.**
- 9. Do not submerge the camera in water or any liquid.**
- 10. Refer all servicing to qualified service personnel. Servicing is required when the apparatus has been damaged in any way, such as power-supply cord or plug is damaged, submerged in liquid, does not operate normally, or has been dropped.**

Model RELPTZ22-1

FCC Compliance

FCC INFORMATION: This equipment has been tested and found to comply with the limits for a Class A digital device, pursuant to Part 15 of the FCC rules. These limits are designed to provide reasonable protection against harmful interference when the equipment is operated in a commercial environment. This equipment generates, uses, and can radiate radio frequency energy and if not installed and used in accordance with the instruction manual, may cause harmful interference to radio communications. Improper operation of this equipment in a residential area is likely to cause harmful interference in which case the user will be required to correct the interference at his or her own expense.

CAUTION: Changes or modifications not expressly approved by the party responsible for compliance could void the user's authority to operate the equipment.

This Class A digital apparatus complies with Canadian ICES-003.
Cet appareil numérique de la classe a est conforme à la norme NMB-003 du Canada.

CE Compliance

WARNING: This is a Class A product. In a domestic environment this product may cause radio interference in which case the user may be required to take adequate measures.



WARNING

The lightning flash within an equilateral triangle is intended to alert the user to the presence of dangerous voltage that may be of significant magnitude to constitute a risk of electric shock.



CAUTION

The exclamation point within an equilateral triangle is intended to alert the user to the presence of important operating or maintenance instructions that should be noted to avoid damage to the equipment or loss of data.

Contents

Features.....	3
What’s in the Box.....	4
Settings	5
Setting Camera Termination.....	5
Setting Camera Address.....	6
Setting Camera Protocol (Optional).....	7
Dimensions	9
Installation.....	11
Considerations	11
Tools Required	11
Mounting.....	12
Flush-Mount Installation	12
Surface-Mount Installation.....	14
Wiring.....	16
Connecting to a Keyboard Controller	18
Connecting to a DVR.....	19
Camera Configuration	20
Getting Started	20
Understanding the Dome Menu.....	21
Camera.....	23
Dome Setup	27
Specifications	36
Troubleshooting	37
Glossary	38

Features

- **22X optical zoom PTZ indoor dome camera**
- **Superb resolution of 580 lines provides high-quality video day or night**
- **High-end features such as Presets, Tours, Auto Scan normally found in cameras costing thousands more**
- **Built-in motion detection**
- **Alarm input and output**
- **Easy-to-use menu system allows setup in minutes**
- **Wide optical range with PTZ provides coverage of large areas with just one camera**
- **Variable speeds for PTZ functions: Slow, Normal and Turbo enable you to customize camera operation**
- **Titling so you can identify camera location**



TIP

Browse the entire manual prior to installing the camera. There is a lot of useful information and tips that will help you to install your system effectively.

What's in the Box

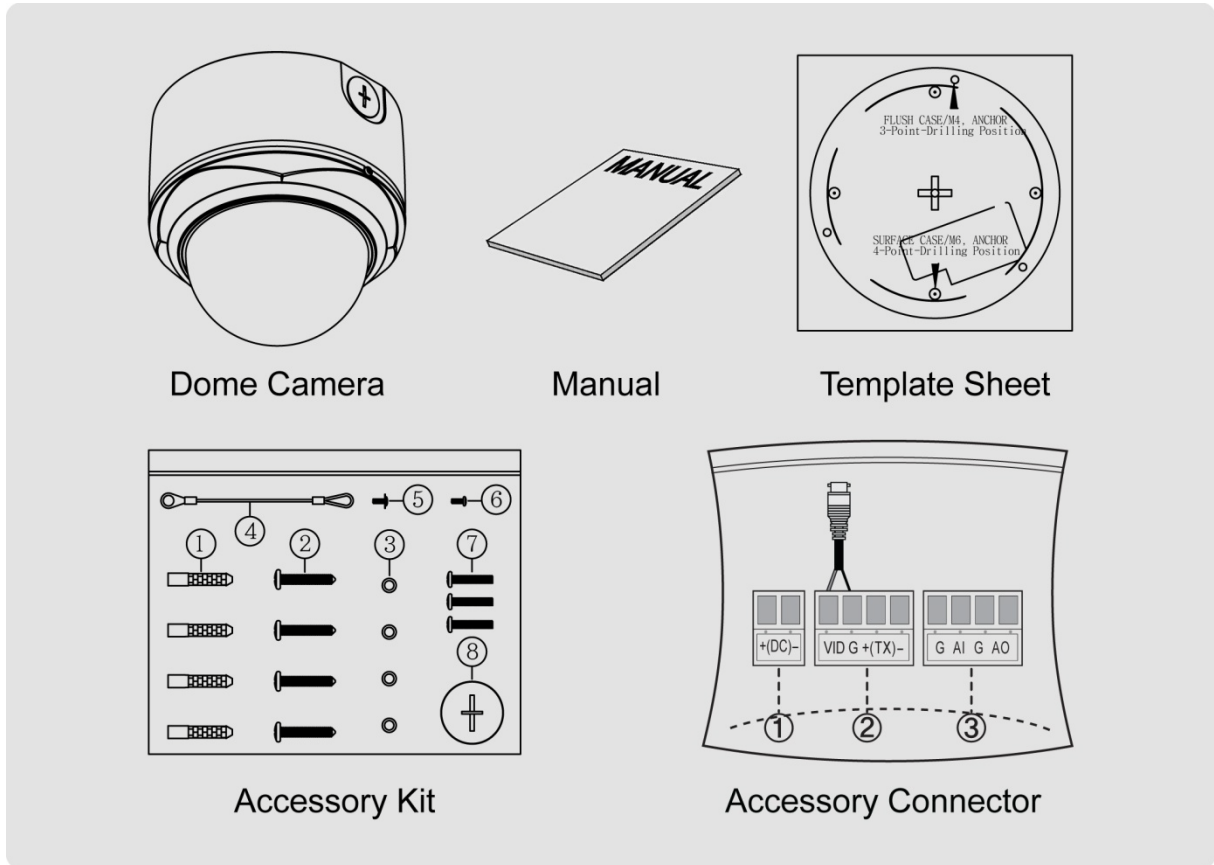

- Dome Camera
- Accessory Connectors for Wiring: 2-pin terminal block (1), 4-pin terminal block and BNC cable (2) and 4-pin terminal block (3)
- Accessory Kit: 4 plastic anchors (1), 4 mounting screws PH6 x 35 (2), 4 O-rings (3), safety lanyard (4), machine screw (NPC 2.6 x 6 (5), 3 machine screws PC 2.6 x 6 (6), machine screw PC 4 x 8 (7) and PT plug (8)
- Template sheet for mounting the camera

Settings

Prior to installing the camera, you must set it up for use in the video system. To do this you will need to access the DIP switches on the bottom of the camera. They are: DOME ID S1 and PROTOCOL S2. Remove the camera from the box and access the DIP switches as shown in Figure 1.



TIP

Use a small paper clip to set the DIP switches to ensure that you set each one correctly.

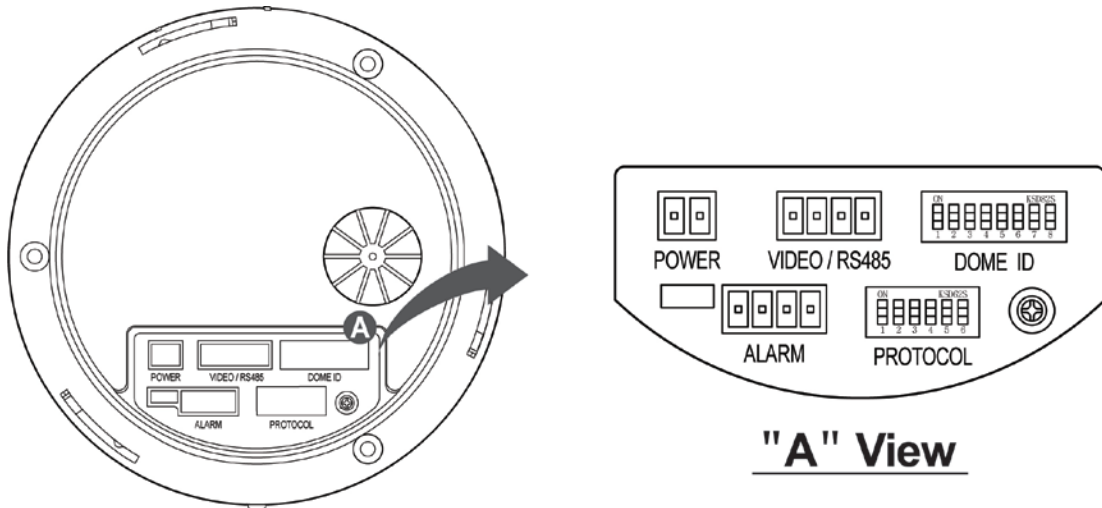

Figure 1. Accessing the DIP Switches



NOTE

Setting DIP switches correctly is very important. If you do not set them correctly, there will be communication errors.

Setting Camera Termination

When you set up your video system, you will be connecting the cameras, keyboard controller and any other devices in a daisy-chain arrangement (maximum of 4,000 feet). All of the devices are set up in a line. The last device in the line must be set so that the control device knows it is the

last device. Set this using DIP switch S2 PROTOCOL (Figure 1). If this camera is to be the last device, set S2-D1 to ON. If it is not the last device, set S2-D1 to OFF.

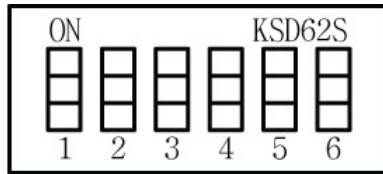

S2

S2	D1
Terminated	ON
Not terminated	OFF



TIP

Set up all of your devices now to ensure that you only have one selected as the last device. Record which device is the last device for future reference.

Setting Camera Address

Each camera requires a unique camera address so that the control device knows which camera is at your back door and which camera is monitoring your driveway. Think of the camera address as a telephone number. In order for the video system to work with multiple cameras, it has to know which one is which.

DIP switch S1 DOME ID (Figure 1) is used to set the camera address. Apply the settings for each camera in your video system as shown in the following table. Up to 255 cameras may be set up. Settings are provided here for eight cameras, either dome or other types. If you are setting up more than 8 cameras, please visit our website at www.revoamerica.com and download our Advanced Features manual RELPTZ22-10AF.



NOTE

This is an important step. If you do not set the camera addresses correctly, there will be communication errors.

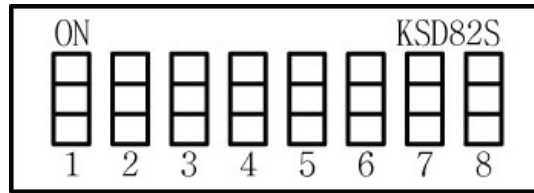

S1 Settings

CAMERA ID	SWITCH NUMBER							
	1	2	3	4	5	6	7	8
1	ON	OFF	OFF	OFF	OFF	OFF	OFF	OFF
2	OFF	ON	OFF	OFF	OFF	OFF	OFF	OFF
3	ON	ON	OFF	OFF	OFF	OFF	OFF	OFF
4	OFF	OFF	ON	OFF	OFF	OFF	OFF	OFF
5	ON	OFF	ON	OFF	OFF	OFF	OFF	OFF
6	OFF	ON	ON	OFF	OFF	OFF	OFF	OFF
7	ON	ON	ON	OFF	OFF	OFF	OFF	OFF
8	OFF	OFF	OFF	ON	OFF	OFF	OFF	OFF

Setting Camera Protocol (Optional)

If you are using a REVO America keyboard controller or not using a keyboard controller at all, and using the camera in the United States or other NTSC standard country, there is no need to change the default settings of DIP switch S2 PROTOCOL (Figure 1). If you need to make changes, see the setting options that follow.

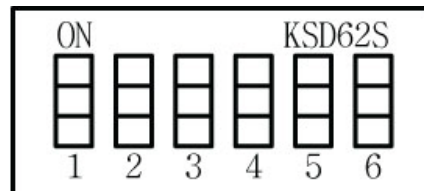

S2 Settings

If you are using a keyboard controller or DVR other than REVO America, check the protocol required and set switch S2-D2, D3 and D4 as follows:

S2			PROTOCOL
D2	D3	D4	
OFF	OFF	OFF	F2, RT, Pelco-P, Pelco-D : (Default)
OFF	OFF	ON	F2, RT
OFF	ON	ON	Pelco-P, Pelco-D



NOTE

Some of the camera features may not be available when using protocols other than the defaults listed above.

To change the BAUD rate to match your keyboard controller, set switch S2-D5 and D6 as follows:

S2		BAUD RATE
D5	D6	
OFF	OFF	2400 bps
OFF	ON	4800 bps
ON	OFF	9600 bps : default
ON	ON	19200 bps

Dimensions

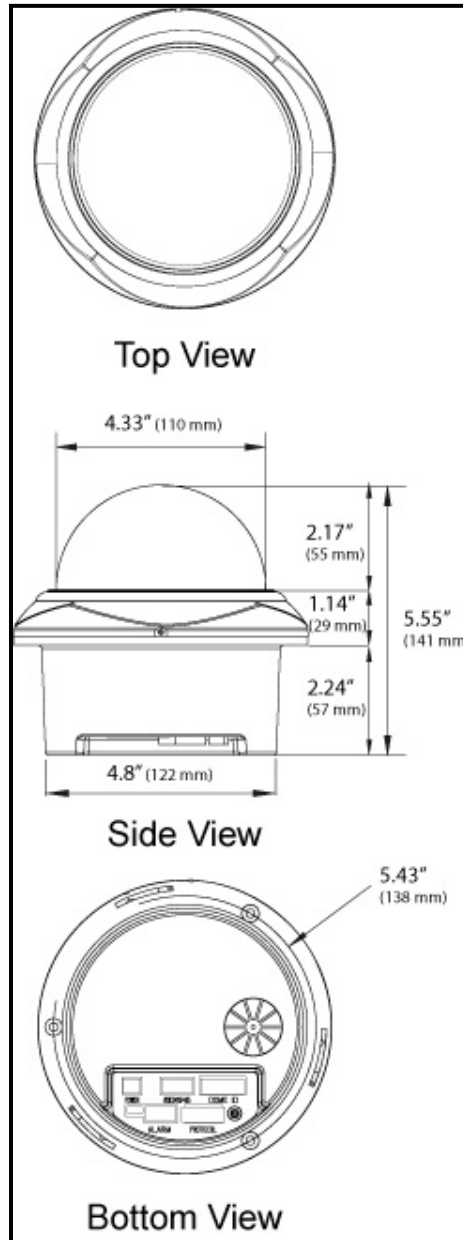

Figure 2. Flush-Mount Case Dimensions

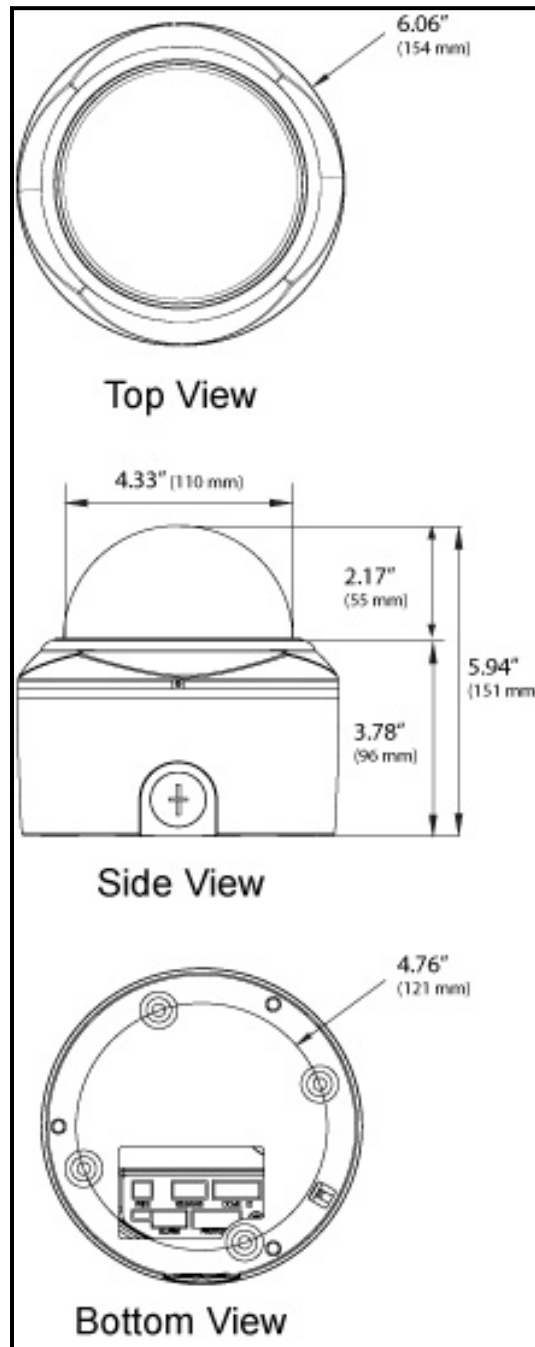

Figure 3. Surface-Mount Case Dimensions

Installation

Considerations

You should carefully consider installation of the camera(s) to ensure a successful and easy installation. The camera may only be used indoors.

Please review the following list prior to starting your installation.

- Camera Location – Cameras should be located in places where they will be protected from direct exposure to the sun, strong light or water immersion. Exposure to any of these will impair video quality and damage the camera.
- Wiring – The cameras are connected to the video system using coaxial cable. They require power from a Class 2 power supply and if you choose to connect alarms or sensors, other wiring. Make sure that you can provide the wiring to the locations that you select, and that power is available for the power supply. Contact REVO America for all the accessories that you will need to install the camera.
- Visibility – The cameras should be mounted so there are no obstructions or blind spots.
- Mounting – The camera should be mounted in a sturdy location capable of supporting its weight (2.4 lbs; 1.1 kg).

TIP



If this is your first time installing a video system, you may want to connect all of the cameras and other devices to the DVR prior to installing and mounting the equipment. This will give you the opportunity to wire the system and ensure you have everything connected properly before you mount the cameras and run the wiring.

Tools Required

There are no special tools required to install the camera. Standard flat and Philips head screw drivers, a power drill and power saw may be required to create access for the wiring required for the camera.

Mounting



WARNING

Never work with power on. You should always disconnect electrical power prior to installation or removal of any equipment.

The camera may be flush or surface mounted depending upon your requirement. A flush-mount installation will provide a more compact installation with ceilings where you can easily cut a hole in the ceiling and mount the Camera Set into the ceiling. Surface mounting works better with hard ceilings, where the best solution is to mount the camera Surface Case to the ceiling.

Instructions for installing the camera using either method are provided below.

Flush-Mount Installation



NOTE

Make sure that you run your power, video and signal cabling for the camera prior to installing it. See the Wiring section.

1. Using the supplied template sheet, mark holes in the ceiling for the Camera Set and the anchors that you will secure the camera to the ceiling with the screws. Cut out the hole for the Camera Set and use a suitable sized drill bit or punch to make the holes for the anchors.

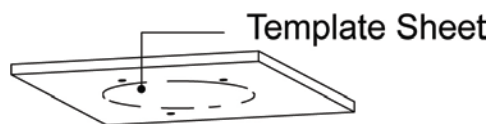

2. Disassemble the Surface Case, Camera Set and Top Case as shown below.

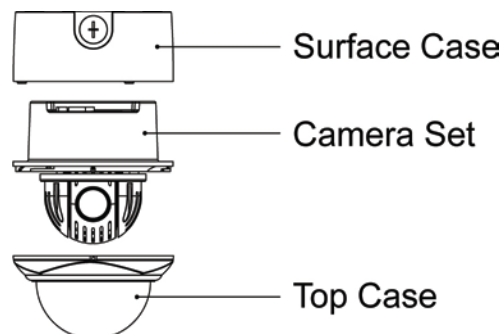

3. Insert 3 plastic anchors in the holes that you made for them in step 1.
4. Insert the Camera Set in the hole that you cut in step 1 and secure it using 3 mounting screws PH6 x 35.

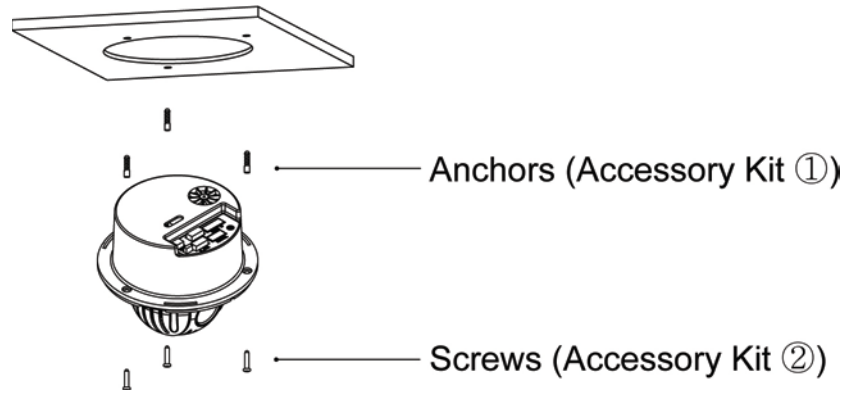

5. Install the Top Case on the Camera Set and turn it clockwise to lock in place. Secure it using a machine screw PC 2.6 x 6 to complete the installation.

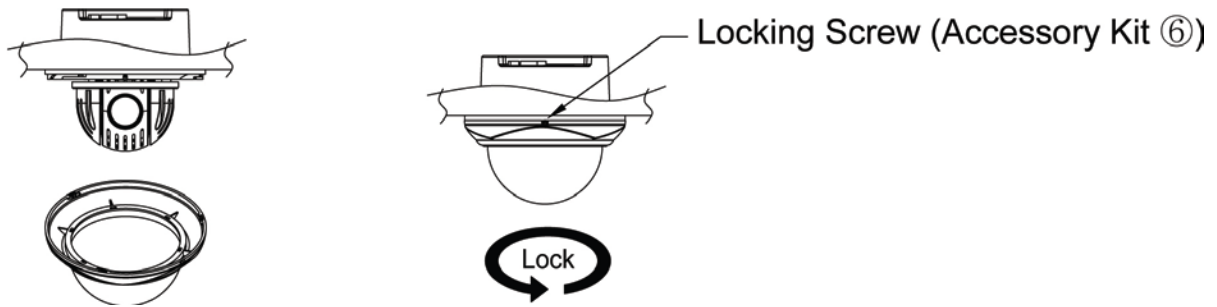

Surface-Mount Installation



NOTE

Make sure that you run your power, video and signal cabling for the camera prior to installing it. See the Wiring section.

1. Using the supplied template sheet, mark holes in the ceiling for the Surface Case wiring access and the anchors that you will secure the camera to the ceiling with the screws. Cut out the hole for the wire access and use a suitable sized drill bit or punch to make the holes for the anchors.

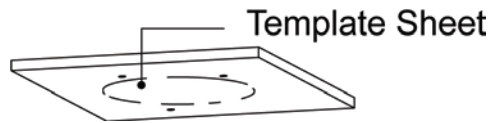

2. Disassemble the Surface Case, Camera Set and Top Case as shown below.

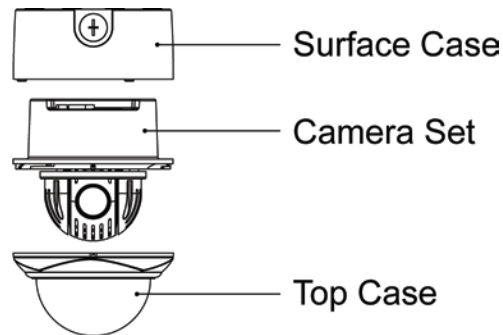

3. Insert 4 plastic anchors in the holes that you made for them in step 1.
4. Attach the Surface Case to the ceiling with 4 mounting screws PH6 x 35.

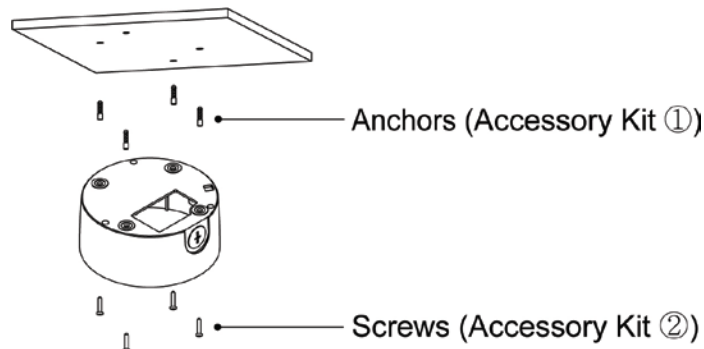

5. Insert the Camera Set into the Surface Case and attach them using the Safety Lanyard, machine screw NPC 2.6 x 6 and 3 machine screws PC 4 x 8.

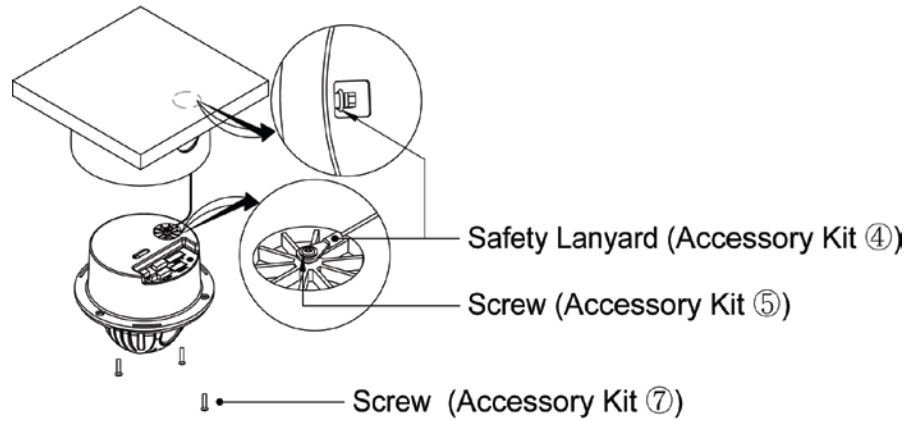

6. Install the Top Case on the Camera Set and turn it clockwise to lock in place. Secure it using a machine screw PC 2.6 x 6 to complete the installation.

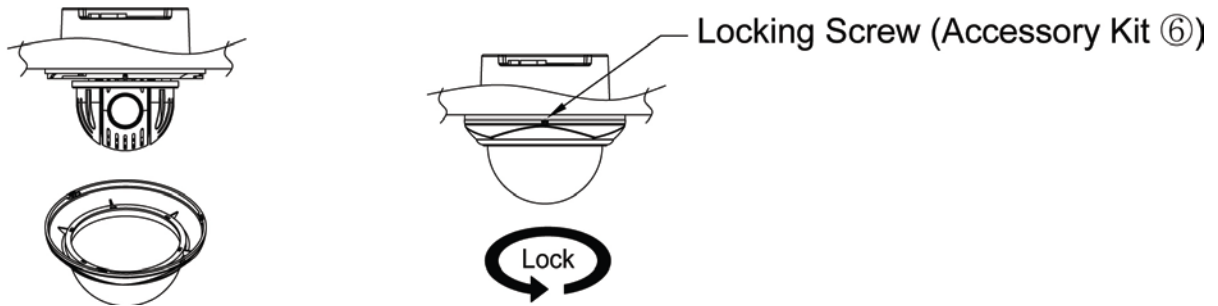

Wiring



WARNING

Never work with power on. You should always disconnect electrical power prior to installation or removal of any equipment.

Wire the dome camera as shown in Figure 4.

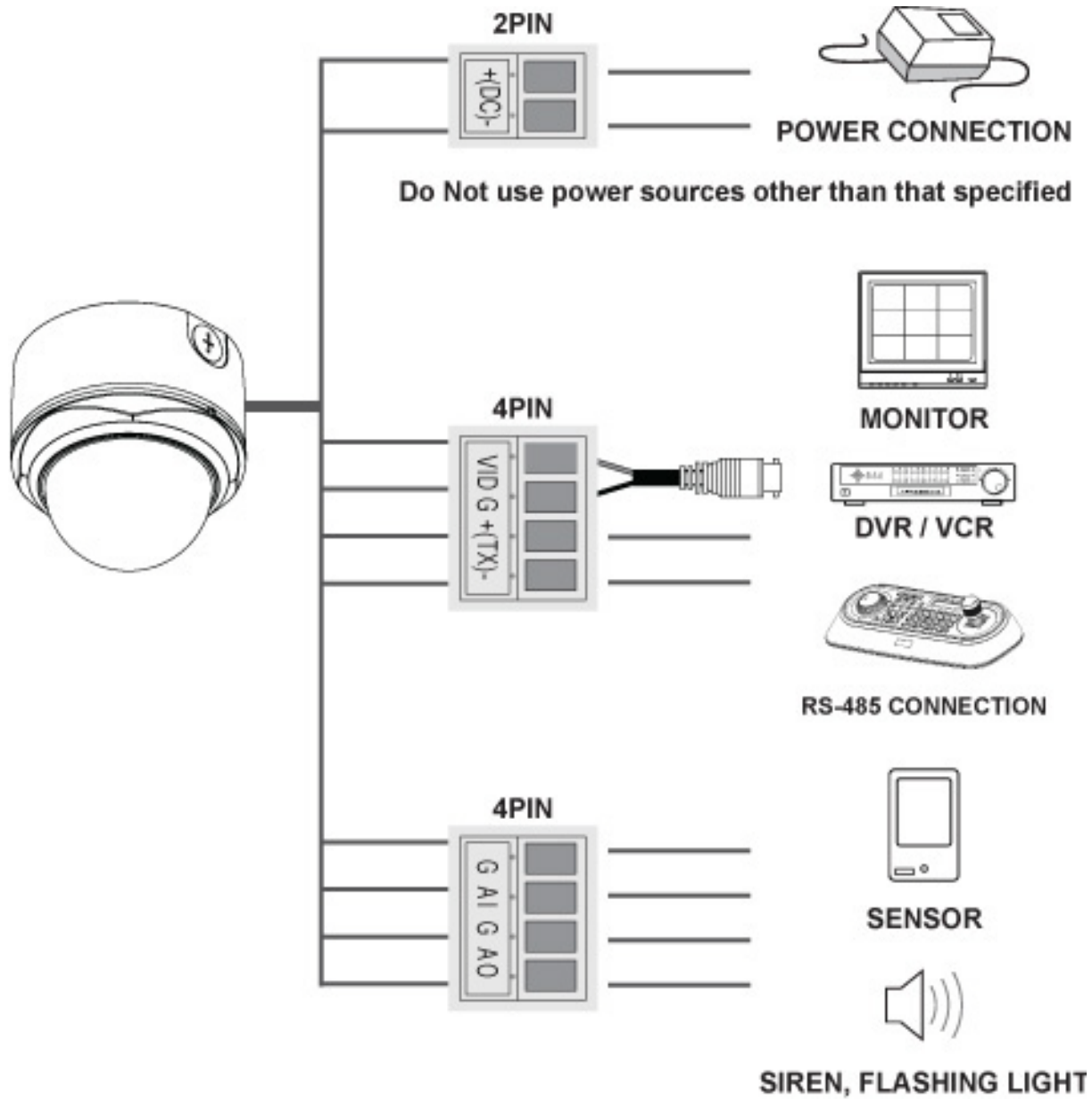

Figure 4. Dome Camera Wiring

- Power In (2-pin)** With power off, connect a certified/listed 12 VDC, 650 mA Class 2 power supply to the dome camera connector. When using a DC 12V adapter, connect the positive (+) pole to the '+' position and the negative (-) pole to the '-' position.
- Video/RS-485 Keyboard Controller (4-pin)** **VID G terminals:** Connect the video out (BNC) connector to the monitor or video input on DVR.
+(TX)- terminals: If you are using a keyboard controller, connect the RS-485 dome camera connector to it (Figure 5). Refer to the keyboard controller manual.
If you are connecting to a DVR, connect the RS-485 dome camera connector to it (Figure 6). Refer to the DVR manual. See Note below.
- Alarm Input and Output (4-pin)** **Alarm Input (AI and G):** You can use external devices to trigger the dome camera to react to an event, such as a door that has an alarm on it being opened. Mechanical or electrical switches can be wired to the AI (Alarm In) and G (Ground) connectors.
Alarm Output (AO and G): The dome camera can activate external devices such as buzzers or lights upon motion detection, using a 5 V TTL output.
G is the common ground.
Refer to the Programming and Operation instructions for more information on using these functions



NOTE

Most DVRs provide a graphical user interface to control the camera and access the camera menu. Refer to the DVR manual to learn how to access the camera functions.

Connecting to a Keyboard Controller

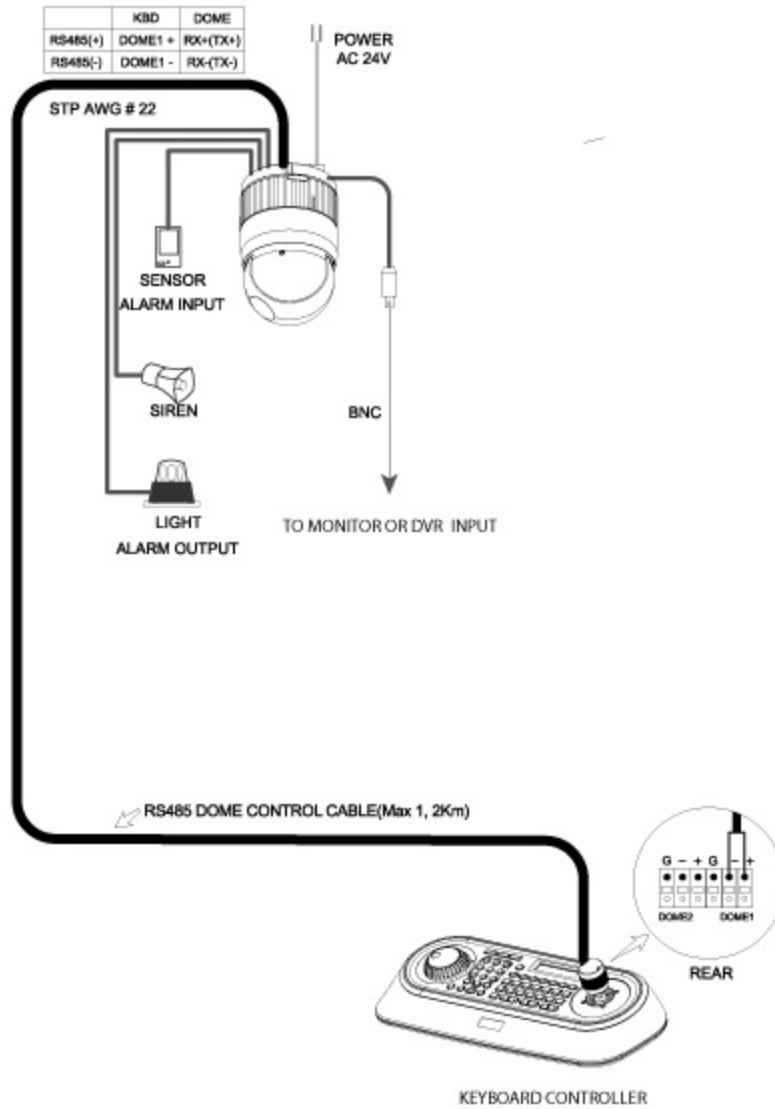

Figure 5. Connecting the Camera to a Keyboard Controller

Connecting to a DVR

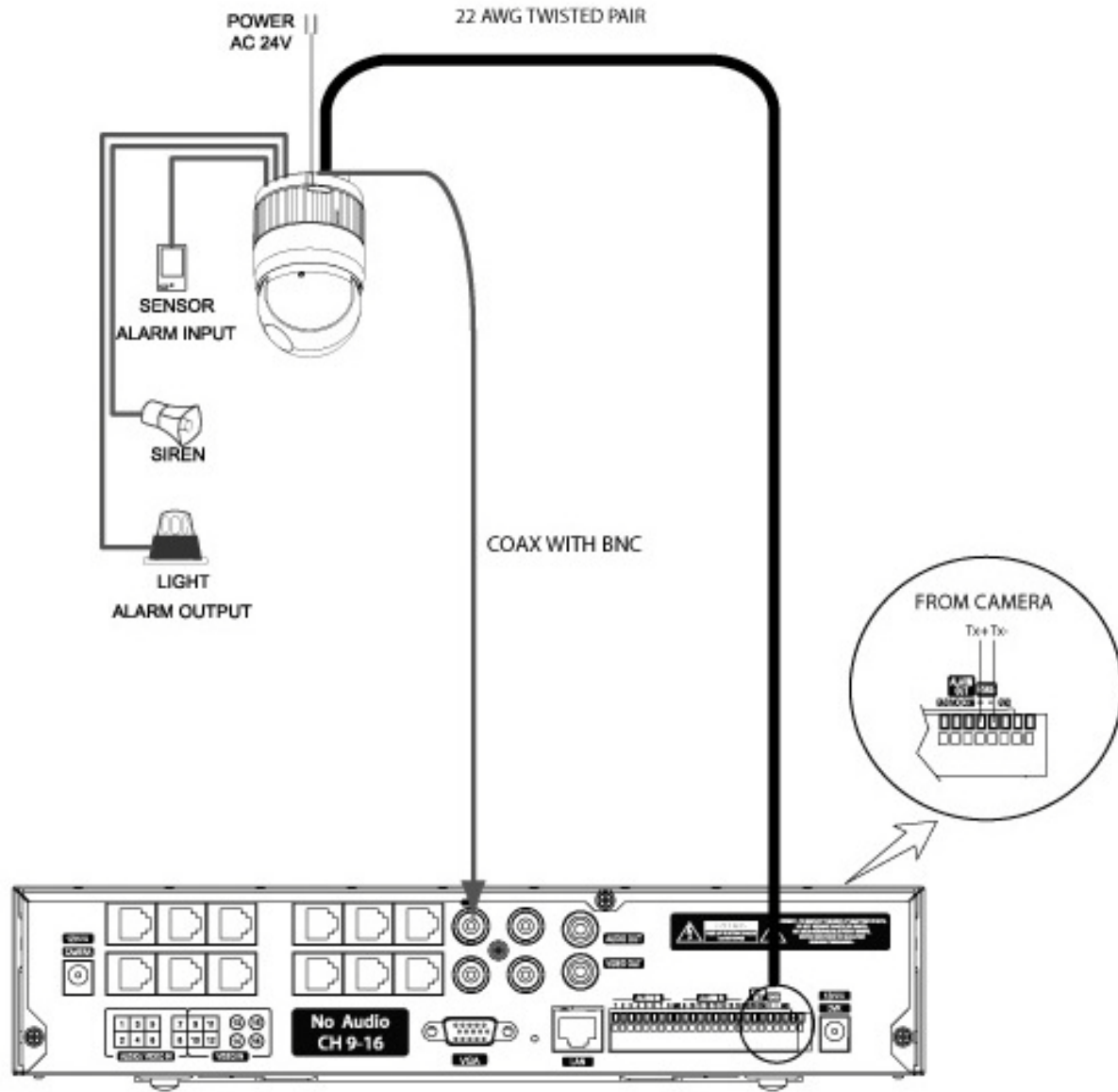

Figure 6. Connecting the Camera to a DVR

Camera Configuration

Now that the system is installed, your next step is to configure the camera for operation. These instructions will guide you through optimizing the camera for use and setting it up for your installation. You can customize the camera's movements and many other functions using the camera's menu system. Please note that for most applications, the default settings that your REVO America camera has will work just fine and should not require any further adjustment.

For the purposes of describing the commands and configurations available on the camera, all commands and operation of the camera will be initiated using a REVO America keyboard controller. This is the ideal setup and offers the greatest flexibility and ease of operation. However, a REVO America DVR may also be used to control the camera, as well as non REVO America keyboard controllers or DVRs, which may be used providing you set the protocols correctly. See the Settings section. Refer to the applicable user manual to determine the equivalent command keys on your device.

Getting Started

Once the system is fully connected, apply power. The DVR, camera and keyboard controller will begin a boot up routine. This will take a few minutes. Once the system is fully powered up, you should see the following.

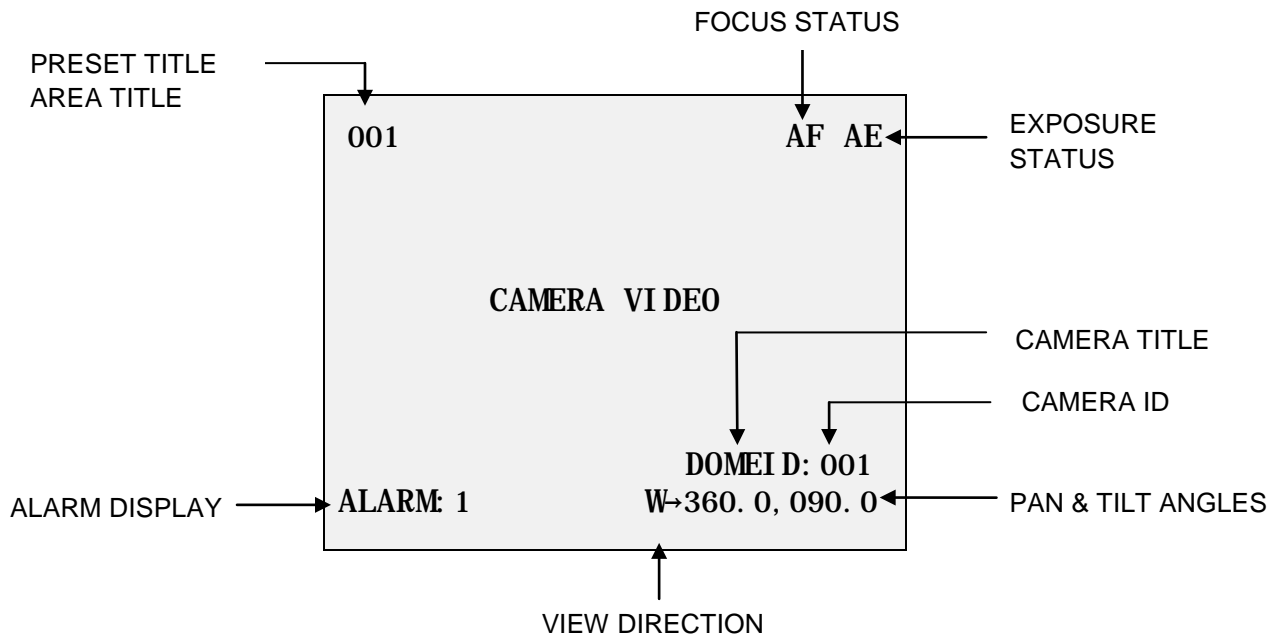

Access the camera menu as follows:

1. Log into keyboard controller by entering the administrator's password. On the REVO America keyboard controller, the default password is: 9999.
2. Select camera by pressing the camera number, for example 1, and then the CAM key on the keyboard controller.
3. Press the MENU key on the keyboard controller. The DOME MENU displays.

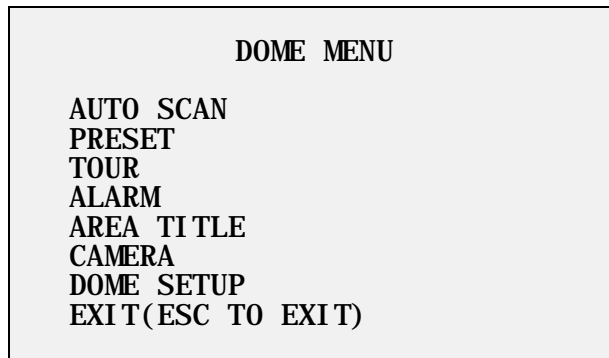

You can make selections on the menu by using the keyboard controller shortcut keys, DVR or non REVO device (depending on the device).

Function	Keyboard Controller Key
Call the on-screen menu utility	MENU
Navigate through the menu items.	Joystick up or down
Go into the sub-menu items.	Joystick left or right
Change value. Enter the editing title mode.	Joystick left or right or Zoom handle twist
Change value of angle	CTRL + Joystick
Escape (EXIT)	ESC

Understanding the Dome Menu

The Dome Menu is the main menu for the camera. From the Dome Menu, you can access all of the functionality of the camera to customize its operation for your video installation. For purposes of this guide, the Camera and Dome Setup menus will be described. The other menus are

described in the Advanced Features manual RELPTZ22-10AF, which is a companion to this manual.

A brief description of the functionality that each menu offers follows:

- Auto Scan** Enables you to set a programmed scan of an area such as a room. You can set the camera to start in one location and move to another location and then back to the starting location at a preconfigured speed. Up to 5 different Auto Scans may be configured. ***Advanced Features manual.***
- Preset** Enables you to create presets, which are programmed video scenes, based on specific pan, tilt, zoom, and focus settings. For example, one preset may be a close up view of the back door, while another may be a window in the same room. Think of a preset as if you had a camera in your hand and were taking photos of various objects in a room. Up to 120 Presets may be programmed for this camera. ***Advanced Features manual.***
- Tour** This menu provides the options for creating tours, which are a programmed sequence of Presets. Up to 4 tours may be programmed. ***Advanced Features manual.***
- Alarm** This menu manages input alarms, which will trigger camera action and output alarms, which may be used to trigger an audio or visual alarm indication. ***Advanced Features manual.***
- Area Title** A user defined name for a specific area that the camera views that has a specific pan and tilt range. This menu guides you through the process of defining and naming the area. ***Advanced Features manual.***
- Camera** This menu sets exposure, focus, white balance, noise reduction and other parameters.
- Dome Setup** This menu sets up both basic, such as the user language, and advanced features, such as how the camera will return to programmed operation after being controlled manually (Home Function Setup).

Camera

Select the Camera option from the Dome Menu to adjust the camera parameters and optimize performance for your installation.

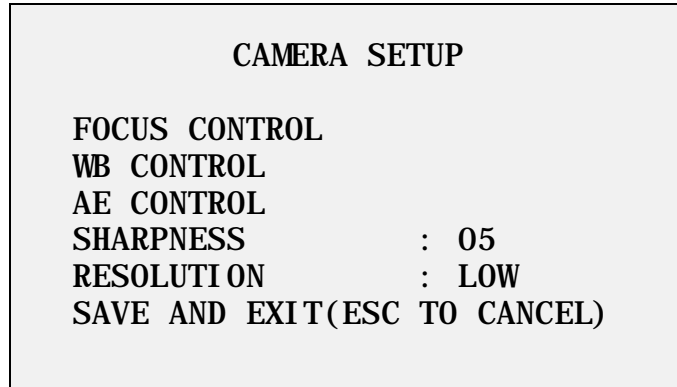

FOCUS CONTROL

The Focus Control submenu controls camera focus options including automatic and manual modes.

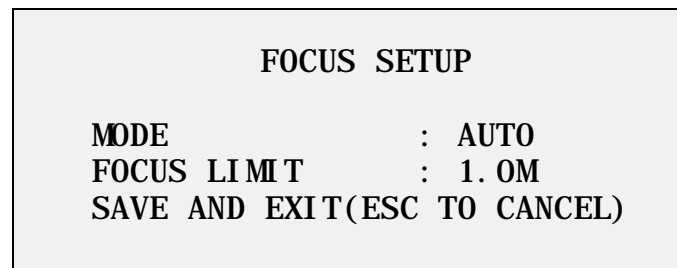

MODE:

AUTO/MANUAL/ONE PUSH/CONSTANT MANUAL

AUTO: Lens in autofocus mode. The lens motor will automatically move the lens to find the best focal point.

MANUAL: Lens is focused manually. For normal use, manual mode should be used.

ONE PUSH: In certain situations, the lens may not be able to find a focal point. This will cause the lens motor to continuously move. Using One Push Focus will choose a point to focus on and lock into that point.

CONSTANT MANUAL: Sets the focal point to where the camera was set,

by the user, to focus and stay there. With manual focus the image that is being focused on can become out of focus due to wind or other factors. Using Constant Manual will adjust the focus for these minor changes by keeping the desired image in focus.

FOCUS LIMIT:

This sets an approximate value that the camera will remain in focus from the setting value. The options are: 3.3' (1 m), 4.9' (1.5 m), 8.2' (2.5 m) and 19.7' (6 m).



CAUTION

Avoid continuous use of the Auto Focus mode. It will shorten the life of the lens.

WB CONTROL

The White Balance WB setup submenu provides control to adjust the color hue (red and blue) gain for a camera so that true white appears white in the image. It is normally compensated for by the automatic gain control (AGC). In some lighting conditions, you may need to manually adjust the red and blue settings for optimal viewing. When Automatic White Balance is enabled, the camera measures the image and automatically adjusts the red and blue settings to balance white. When automatic white balance is disabled, the camera uses the values set for the red and blue gain to balance white.

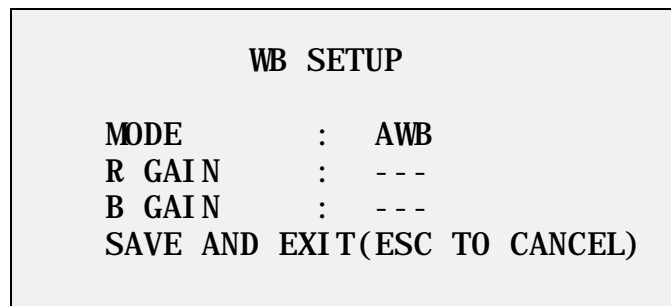

MODE:

AWB/WAWB/INDOOR/MANUAL

AWB: Automatic white balance computes the white balance value output using color information from the entire screen automatically. Color range from 2500 to 9500 °K.

WAWB: Wide range automatic white balance mode. Color range from 1800 to 10500 °K.

INDOOR: Indoor white balance mode. Optimized for indoor use.

OUTDOOR: Outdoor white balance mode. Optimized for outdoor use.

MANUAL: Enables setting of RGAIN (Red) and BGAIN (Blue) manually to obtain white balance.

RGAIN: Red Gain. Adjustable from 0-255.

BGAIN: Red Gain. Adjustable from 0-255.
RGAIN / BGAIN modes are controllable only in MANUAL mode.

AE CONTROL

The AE Setup submenu provides setting options for automatic and manual exposure to obtain the best exposure settings to provide a well exposed video scene.

AE SETUP	
MODE	: MANUAL
GAIN	: MIN
BRIGHT	: 024
SHUTTER	: 1/50
FLICKERLESS	: ---
BACK LIGHT	: OFF
WDR	: ---
WDR LEVEL	: ---
NIGHT SHOT	: AUTO
SAVE AND EXIT(ESC TO CANCEL)	

MODE: AE1/AE2/SHUTTER PRIO/MANUAL

AE1: Auto Exposure automatically calculates and adjusts exposure settings to ensure that objects in the video scene are visible and rendered properly with respect to each other. Auto exposure mode1 is used indoors.

AE2: Auto Exposure mode 2 is used to compensate for high brightness, such as an extremely sunny room.

SHUTTER PRIO: Shutter Priority sets the shutter as the controlling factor in determining the lens opening and exposure of a scene. For example, areas with a lot of movement require higher shutter speeds to ensure that the scene remains in focus.

MANUAL: User controlled shutter and Gain settings.

GAIN: Use to increase exposure level of video in Manual mode. MIN/LOW/MID/HIGH.

BRIGHT: 10-50.

SHUTTER: Manually sets shutter speeds. 1/60, 1/120, ..., 1/2000, 1/10000, 1/100000.

FLICKERLESS: Compensates for flicker. ON/OFF.

BACK LIGHT: Compensates for bright background. ON/BLC/HLC. BLC allows the camera to adjust the exposure of the entire image to properly expose the subject in the foreground. HLC improves the ability of the camera to display shades of gray elsewhere in the picture. Note that focus issues may occur when using BLC or HLC.

ATR: Automatic Tone Reproduction. ATR provides gradation compensation to improve the contrast of subjects whose gradation has been lost in cases where both low-luminance areas and high-luminance areas exist in the same picture. ON or OFF.

DNR: Digital Noise Reduction evaluates each frame of the image to provide clean images. Settings are OFF or 1-7.

NIGHT SHOT: The camera uses an IR cutoff filter, which blocks infrared light to accurately render color images. The Night Shot feature removes the IR cutoff filter, so that the camera can produce images in low light environments. The settings are:

AUTO: Camera automatically goes to B&W mode in low light.

GLOBAL: Controlled by the keyboard controller (REVO America). The operator can enable Night Shot for all dome cameras at the same time. If the Night Shot mode is set to GLOBAL, pressing 999 + ENTER on the

keyboard controller will turn off Night Shot mode. Pressing 888 + ENTER on the keyboard controller will turn on Night Shot mode.

ON: B&W mode.

OFF: Color mode.

SHARPNESS: Used to control picture sharpness. The higher the setting (0-15), the sharper the picture.

RESOLUTION: Selects the resolution mode. (LOW / MID / HIGH).

Dome Setup

From the DOME MENU, navigate to the DOME SETUP menu item and select it. The CONFIGURATION MENU displays.



NOTE

Many of the features described in this section, such as Presets, Tours, Alarms, etc. are described in the Advanced Features manual REVDPTZ22-10AF.

CONFIGURATION MENU

```
LANGUAGE      : ENGLISH  
HOME FUNCTION SETUP  
OSD DISPLAY  
VIEW ANGLE SETUP  
INITIALIZE DATA  
SYSTEM MENU  
SYSTEM INFORMATION  
SAVE AND EXIT(ESC TO CANCEL)
```

LANGUAGE Selects the language that you want to use for the menu display. English, French, German, Italian, Spanish, Polish or Portuguese are options.

HOME FUNCTION SETUP Displays the following submenu:

HOME FUNCTION SETUP

HOME FUNCTION : PRESET
FUNCTION NUMBER : 10
WAITING TIME : 120 SEC
FUNCTION ENABLE : ON
SAVE AND EXIT(ESC TO CANCEL)

The **Home Function** defines the camera's normal operation when left unattended. The Home Function, once programmed, will return the camera to its normal or programmed operation after manual control of the camera has stopped. For example, if you are using the keyboard controller or DVR to manually zoom, pan or tilt the camera to view something of interest, setting the Home Function to one of the functions will program the camera to automatically begin one of the following: None/Tour/Auto Scan/Preset, after a user defined waiting time.

In the example shown above, the camera will go to Preset 10, 120 seconds after manual control has stopped, when Function Enable is set to ON. If NONE is selected or Function Enable is set to OFF, the scene will remain where the manual control stopped.

HOME FUNCTION: None/Tour/Auto Scan/Preset.

FUNCTION NUMBER: The number of the Tour, Auto Scan or Preset that you want to start.

WAITING TIME: The amount of time the system will wait before starting the Home Function. You can set it for 10~240 seconds.

FUNCTION ENABLE ON/OFF. Set to ON to enable the Home Function.

OSD DISPLAY SETUP

The OSD Display Setup menu allows you to customize the camera display. You can select what information you want to display and select the location on the screen where you want it to display.

OSD DISPLAY SETUP

CAMERA TITLE : DOMEI D
VIEW DIRECTI ON : OFF
DOME OSD : ON
AREA TITLE : OFF
PRESET TITLE : CONSTANT
FOCUS EXPOSURE : ON

SAVE AND EXIT(ESC TO CANCEL)

CAMERA TITLE: Creates a name for the camera. Up to 6 characters.

VIEW DIRECTION: ON/OFF. ON sets the current direction as N (North) and the coordinate angle to 000. Every 90 degrees of clockwise rotation will change the title to E (East), S (South), W (West). If you use the ON/OFF option frequently, it is recommended that you set “North” as a Preset. Recall the “North” Preset before enabling the directional title. OFF turns the direction indication off.

DOME OSD: ON/OFF. When set to OFF, the OSD does not display.

AREA TITLE: ON/OFF. When set to ON, the Area Title displays as the camera moves.

PRESET TITLE: CONSTANT/OFF/. Sets the Preset title ON or OFF.

FOCUS EXPOSURE ON/OFF. When set to ON, the Focus and Exposure settings display. For example, Auto Focus (AF) and Auto Exposure (AE).

VIEW ANGLE SETUP Displays the following submenu.

VIEW ANGLE SETUP

FLIP : AUTO
TILT LIMIT : OFF
SAVE AND EXIT(ESC TO CANCEL)

The View Angle Setup menu enables you to set flip angle and tilt limit.

FLIP:

OFF/AUTO.

OFF: The dome camera moves until it reaches 90° vertically.

AUTO: When the camera reaches the floor directly above the moving object, it stops. At that time, release the joystick instantly and pull it down again to run the auto-flip function.

TILT LIMIT:

This option limits the view angle when there is an obstruction in zooming out on specific area of the tilt angle.

ON: When this option is enabled, the range of the tilt angle will be limited to 10°.

This will prevent a viewing obstruction or focus problem caused by the horizontal line of the semi-sphere in the bubble.

OFF: When this option is disabled, the range of the tilt angle will not be limited.

When you zoom out within the range of the tilt angle, you will see the horizontal line of the semi-sphere in the bubble.

INITIALIZE DATA

The Initialize Data submenu will allow you to reset some or all of the factory default settings and erase any programming that you have done.



CAUTION

Use care when accessing the Initialize Data menu. Depending upon your selections, it will erase all your custom settings.

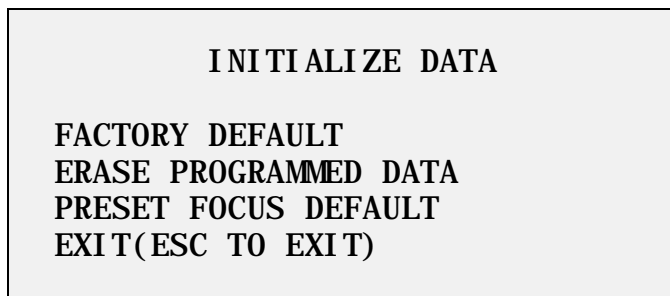

FACTORY DEFAULT Selection of Factory Default displays the following submenu.

```
FACTORY DEFAULT
ARE YOU SURE ?
CANCEL
OK
```

Selecting OK will restore the factory defaults and delete any changes that you have made.

ERASE PROGRAMMED DATA Selecting this submenu will enable you to choose which of the data that has been stored on the camera's Flash-ROM you wish to erase. You will be asked to enter ON or OFF. If you desire to erase all data then select ERASE, otherwise press the **ESC** key on the keyboard controller to exit without erasing. The erased data includes all stored data (Auto Scan, Preset, and Tour....).

```
ERASE PROGRAMMED DATA
AUTO SCAN      : ON
PRESET         : ON
TOUR           : ON
ALARM          : ON
AREA TITLE     : ON
CAMERA         : ON
DOME SETUP     : ON
ERASE
SAVE AND EXIT(ESC TO CANCEL)
```

PRESET FOCUS DEFAULT Selecting the Preset Focus Default submenu allows you to select the default focus mode of the camera. The choices are: AUTO/MANUAL/ONE PUSH.

PRESET FOCUS DEFAULT
FOCUS : AUTO
SAVE AND EXIT(ESC TO CANCEL)

SYSTEM MENU

This submenu enables you to change system parameters and set a password.

SYSTEM MENU
MOTOR SETUP
PASSWORD EDIT
ORIGIN CHECK
WHITE DEFECT COMPENSATION
CALIBRATION : ON
PASSWORD ENABLE : OFF
BLINK CURSOR : ON
DOME ANSWER : ON
SAVE AND EXIT(ESC TO CANCEL)

MOTOR SETUP

You can set the dome pan and tilt motor speed with this submenu.

MOTOR SETUP
PROPORTIONAL P/T : ON
P/T MODE : NORMAL
SAVE AND EXIT(ESC TO CANCEL)

PROPORTIONAL P/T : ON / OFF

P/T MODE : SLOW / NORMAL / TURBO

- SLOW MAXIMUM SPEED** : 40°/second
- NORMAL MAXIMUM SPEED** : 90°/second
- TURBO MAXIMUM SPEED** : 380°/second



NOTE

Pressing and holding the **CTRL** key on the keyboard controller while moving the joystick will enable it to operate in the Turbo speed mode regardless of the setting.

PASSWORD EDIT

You can change the password with this menu. Password length is 6-digits or characters. The default password is 555555. When password enable is on, the input password window displays to enter the menu. To set a new password, select the character or number with the joystick and press the **CTRL** key on the keyboard controller to use that character.

PASSWORD EDIT SETUP
(CTRL KEY)

INPUT PASSWORD
PASSWORD :

A B C D E F G H I J
K L M N O P Q R S T
U V W X Y Z 0 1 2 3
4 5 6 7 8 9 ()

SAVE AND EXIT(ESC TO CANCEL)

ORIGIN CHECK

If the camera is out of position during operation and you want to reset it to the origin position, using this function will reset it.



WHITE DEFECT COMPENSATION Compensates for white defects (bad pixels) in the camera CCD sensor.

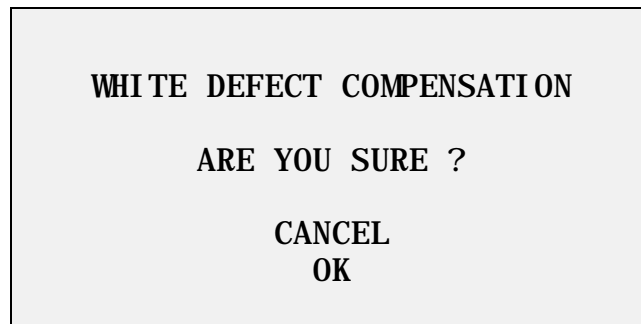

- CALIBRATION:** ON(Auto origin check) / OFF.
- PASSWORD ENABLE:** ON. Requires the password to enter menu.
 OFF. No password required. The default password is 555555.
- BLINK CURSOR:** ON. OFF (No blinking cursor).
- DOMES ANSWER:** ON. OFF (Does not acknowledge commands from the dome).

SYSTEM INFORMATION Displays the camera system information. This is useful if service is required. From this screen, you can determine the camera type, hardware and ROM versions.

SYSTEM INFORMATION

CAMERA TYPE : xxxxx-xxxxxx
H/W VERSION : Vx.xx
ROM VERSION : Vx.xx
PROTOCOL : xxxx
BAUDRATE : 9600

EXIT(ESC TO EXIT)

Specifications

Image Device:	1/4" Super HAD CCD II
Optical Zoom:	22X
Resolution:	580 TVL
Focal Length:	f = 3.9 - 85.8 mm
Angle of View:	3.9 mm - 49.5° Horizontal 85.8 mm - 2.4° Horizontal
Aperture:	f/1.6 – f/3.7
Sensitivity:	Normal: 0.05 fc (0.5 lux)
ICR On (Day/Night):	Yes
Motion Detection (in Preset):	Yes
Tilt Angle:	0° - 90° (Auto Flip)
Auto Calibration:	0.1° - 6°
Panning Angle:	360° continuous rotation
Alarm	1 input (NC/NO), 1 5V TTL output
Auto Scan:	1 Auto Pan & 4 Auto Scans
Preset:	120 presets
Tour:	4 tours (42 Presets for each Tour)
Maximum Speed:	240° /sec.
Area Titles:	8 titles with 12 characters each
Input Voltage:	12 VDC ± 10% @ 650 mA
Power Consumption:	8 W
Control Protocol:	RS-485; Baud rate: 2400~19.2k bps (default: 9600 bps)
ID (Camera Address):	1 - 255
Dimensions:	See Figures 3 and 4.
Weight	Approx. 1.1 kg
Operating temperature	32° to 104° F (0° to 40° C)
Operating humidity	0 to 90% relative, non-condensing
Storage temperature	-4° to 140° F (-20° to 60° C)

Specifications are subject to change without notice.

Troubleshooting

Prior to calling product support, verify the installation of the camera as described in this manual. If everything is connected correctly, check the following:

Problem	Possible Solution
No video	<ul style="list-style-type: none"> • Verify that power is connected to all pieces of equipment in the system. • Verify that the power switches are in the ON position. • Check the video connections.
Poor video quality	<ul style="list-style-type: none"> • Check that the BNC connectors are inserted properly. • Check the voltage level of the dome camera. • Cable for video is shielded.
Dome cameras lose their positions	<ul style="list-style-type: none"> • Reset the cameras using the Dome Setup menu. • Check that the dome camera is inserted properly in the base. • Check the voltage level of the camera.
Camera number does not match the multiplexer number.	<ul style="list-style-type: none"> • If using a multiplexer. Check the camera ID and insert the BNC cable into the proper input of the multiplexer.



CAUTION

Do not open the camera or attempt repair of the internal parts.

Glossary

Alarm Action

The assigned response for the dome camera when an input changes from a normal to an abnormal state. This is known as an Input Alarm. The response may be for the camera to run a Preset or have no assigned action.

The dome camera may also send an alarm state to the host controller for processing. This is known as an Alarm Output. See also Input Alarm and Normal Input State.

Area

Programmed start and end points of the dome's field of view around its axis. Each area is a part of a circular viewing area that extends around the dome. The areas can be different sizes. Up to 8 areas can be programmed for the dome. Each can have its own title.

Automatic Gain Control (AGC)

Allows for the amplification of the video signal in scenes with minimal ambient light. Typically, low-light scenes result in picture noise. As gain is increased, the picture noise is also amplified. When AGC is enabled, the value of the gain setting is based on feedback from the camera. When AGC is disabled, the camera uses the value set for the manual gain setting. The trade-off between picture level and noise may be adjusted when AGC is disabled.

On-Screen Menu

The text overlay menu system used for setting dome features. The utility is accessed using a by pressing the **MENU** key on the keyboard controller or by accessing the menu through a DVR. The utility provides settings for camera functions, zoom, alarm, text display, and password protection.

Flip

Allows the dome to automatically reverse the view from bottom to top, 180 degrees when the camera tilts to its lower limit and stays in that position for a brief delay. When the dome flips (rotates), the camera starts moving upward as long as the tilt control is kept in the down position. Once the control is released, the tilt control returns to its normal operational mode. The flip feature is useful when you need to track someone who walks directly beneath the dome and continues on the other side.

Home Position

The default position to which the dome camera returns after an assigned period of inactivity passes. The default position may be a Preset, Tour or No Action.

Input Alarm

A connection point on the dome camera that enables the system to monitor Input Devices. There is one alarm input.

Input Device

An external device that provides information about the condition of system components that connect to the input on the dome camera. Typical input devices include door contacts, motion detectors or smoke detectors.

IR Mode

A feature of the camera that permits manual or automatic switching between color and IR (black-and-white) operation when light levels are low. When IR mode is active, clearer images may be obtained under low-light conditions.

Normal Input State

Describes the expected state of a device connected to dome camera's input. The normal state may be open or closed. When a device is not in its normal input state, an alarm is issued.

North Position

User-definable setting that may correspond to magnetic north or some well-known landmark. Used to approximate the camera dome's pointing direction when Direction Indicators are enabled.

Preset

Programmed video scene, based on a specific pan, tilt, zoom, and focus settings. Up to 120 Presets may be programmed for the dome camera.

Vector Scan

Allows the camera to move from start point to end point including tilt and zoom simultaneously and linearly.

White Balance

Adjusts in the color hue (red and blue) gain for a camera so that true white appears white in the image. It is normally compensated for by the automatic gain control. In some lighting conditions, you may need to manually adjust the red and blue settings for optimal viewing. When Automatic White Balance is enabled, the camera measures the image and automatically adjusts the red and blue settings to balance white. When Automatic White Balance is disabled, the camera uses the values set for the red and blue settings to balance white.

22 X INDOOR PTZ DOME CAMERA